



201 Main St. | Box 219 | Lipton, SK S0G 3B0 | Ph: 306-336-2505 | Fx: 306-336-0508

## WELCOME NEW RESIDENTS

### GENERAL

- The Village Office is open Monday – Friday 8:00 a.m. – 5:00 p.m., open over lunch.
- Our website is [www.villageoflipton.com](http://www.villageoflipton.com). Here you will find coming events, information about the Village, and copies of frequently referenced bylaws.
- We also have a facebook page that we post to frequently about all kinds of interesting topics. Search Village of Lipton on facebook. The correct page will have the Village logo as a profile picture.
- We publish a monthly Newsletter. Paper copies are available at the Office, post office, and library. It is posted on Facebook and on our website. You can also subscribe to have it emailed to you. If you have an event/item for the newsletter please let the office know.

### WATER BILLING

- Water meters are read every month and are read remotely.
  - Billing dates for water and sewer are the first of each month.
  - Monthly minimum usage rates are \$96.00. This is a base rate, and is charged regardless of how little water you use. If you use more than 3,000 gallons of water in a month, there is an overage charge of \$11.50 per 1,000 gallons over.
  - If you need your water shut off for any reason (e.g. moving, going away for an extended period of time, etc.) you must inform the office otherwise the base rate will still be charged monthly. There is a \$50 fee for shutting off/turning on service, and must be done when a homeowner is present.
  - A water deposit of \$100.00 is required by assessed owners and is refundable should you sell your property.
  - Water bill and tax payments may be made online with the Village of Lipton set up as a payee. Use the account number (without any spaces) on your water and tax bills to set up a payment. We are listed as Lipton (Utilities) or Lipton (Tax).
  - We also accept e-Transfers for payment. Payments can be sent to [lipton@villageoflipton.com](mailto:lipton@villageoflipton.com). In the memo please include what the payment is for and your address. The Village is registered for auto-deposit therefore a security question is not required.
  - We offer preauthorized debit as a form of payment for utilities only. The form can be requested at the office. You will need to provide a VOID cheque. The payment is withdrawn from your account sometime between the 1<sup>st</sup> – the 10<sup>th</sup> of every month.
  - We also accept debit, cash, and cheque in office. We are currently not set up to accept credit card payments.
-

## GARBAGE PICK UP

- Garbage pickup days are usually Tuesday or Wednesday unless we are delayed due to weather or equipment repairs.
- Do not leave water in the bottom of the bins
- All garbage MUST BE BAGGED and inside your bin. Loose garbage in or around bins, or garbage bags in improper locations will not be picked up.
- Ensure your bins are in good condition. Broken lids, sides, etc., should be repaired.
- Your bin must be big enough to hold two weeks of garbage. Suggested specifications are below. Please note that bin lids should have hinges and a chain so the lid cannot fall all the way back when opened.

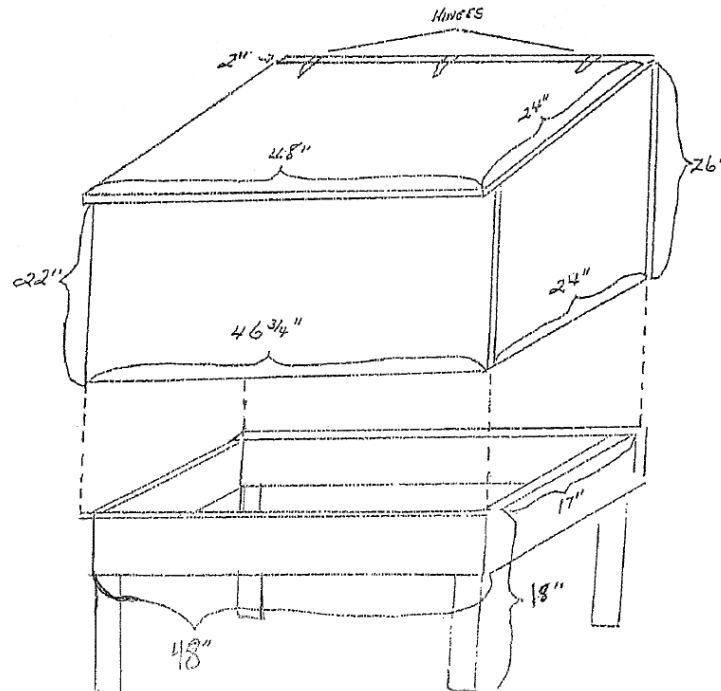

- Garbage bags should not be over 25lbs max.
- Make sure there are no safety hazards near or inside your bin, such as insect nests or broken glass.
- Do not let your bin become tree covered and difficult to access.
- Do not put unbagged dog droppings/cat litter in the bins
- Cement, rocks and tires are not household garbage and will not be picked up.
- All leaves and grass clippings must be bagged in clear garbage bags or recyclable paper bags. Trees and branches must be cut into 4ft lengths, and stacked neatly in the alley in a location that does not impede the use of the alley in order for them to be picked up. These items may also be deposited in the designated piles along the lagoon road.
- The Village offers composting. Compost dumped in alleys will not be picked up, it must be bagged. Do not put garbage, diapers, dog droppings, plastic containers, plastic bags, or any other items in that are not compostable. If these items are included, compost will not be picked up. There is now a bin for compost out at the lagoon. Please dump your bags into the bin and the bin only. Please do not put plastic bags and containers into the compost bin. If the Village notices that improper items are continually put in the compost, the service will be discontinued.
- Cardboard will not be picked up—please deposit flattened boxes in the BLUE SINGLE STREAM RECYCLING BINS across from the Village Office. A list of recyclable items is included.

- Left over paint, empty paint cans, aerosols and electronics (TV's, VCR's, computers etc.) are not part of residential garbage and will not be picked up. You must take these items to Sarcan in Fort Qu'Appelle. Check [www.sarcsarcan.ca](http://www.sarcsarcan.ca) for specifics.
- North Valley Waste Management Authority takes loads of garbage as well as hazardous waste. A list of allowable hazardous waste is included. More information can be found at [www.northvalleywaste.ca](http://www.northvalleywaste.ca).

**November 1-April 30:**

Monday-Friday. 9:00 a.m. – 4:00 p.m. Saturday. 9:00 a.m. – 1:00 p.m.  
Closed Sunday & Stat. Holidays

**May 1-October 31:**

Monday-Saturday. 8:00 a.m. – 5:00 p.m. Sunday. 10:00 a.m. – 4:00 p.m.  
Closed Stat. Holidays

## **SNOW REMOVAL**

- Snow will be removed from the streets as soon as possible after a snowfall event. Public Works begins at roughly 7:30 a.m. with the school area, Main St. and other business areas, then carries on to the rest of town.
- After a snowfall please refrain from parking on the street if possible. This allows Public Works to do a cleaner job of snow removal. If cars are left on the street during cleaning, and ridges left around the car are not the responsibility of the Village.
- Please stay out of the way. With the snow blowing from the blower Public Works cannot easily see you if you are to drive or walk in front of them.

## **DOGS**

All dogs are required to be licensed, must be kept on your own property at all times and must be kept quiet. Dog licenses are \$10.00 and are obtainable at the Village Office. A maximum of two dogs are allowed per house hold. The Dog Bylaw is available on the Village website. Violations of the bylaw may result in fines.

## **CATS**

All cats must be licensed. Free cat tags are available at the Village Office Cats must be confined in an enclosure or on a leash. A maximum of two cats are allowed per household.

## **CABLE TV**

For more information call Access Communications 1-866-363-2225 or [www.accesscomm.ca](http://www.accesscomm.ca)

## **LIBRARY**

1103 Shamrock Ave. 306-336-2288  
Wednesdays. 11:00 a.m. – 5:00 p.m.  
Thursdays. 12:00 p.m. – 6:00 p.m.

---



# SINGLE STREAM RECYCLING

Single-stream recycling is a system in which all recycle materials - fiber, plastics, glass, tin and aluminum - are placed, unsorted, in the BLUE Recycle Cart or Container.

**Cardboard, Boxboard, Office Paper, Newsprint, Junk Mail, Magazines and Catalogues**

**Plastic Containers, Milk Cartons & Plastic Milk Jugs, Shrink Wrap & Plastic Bags** - Plastics numbered 1 through 7

No oil containers or chemical jugs

**Glass** (Food and beverage containers – must be rinsed)

**Tin and Aluminum Cans** (cans must be clean, with or without labels – no steel or auto parts)

The following is a list of items by area to help in knowing what to recycle.

### Laundry

- Laundry soap containers
- Sport remover bottles
- Plastic hangers
- Dry cleaning plastic bags
- Bleach containers
- Plastic Laundry baskets

### Bathroom

- Shampoo bottles
- Body wash bottles
- Conditioner bottles
- Plastic hair spray bottles
- Plastic shaving containers
- Toilet paper cores
- Tissue boxes
- Plastic pill bottles

### Kitchen

- Milk jugs & Milk cartons
- Creamer cartons & bottles
- Paper egg cartons
- Soup, Vegetable, and any other food cans
- Aluminum and tin cans
- Pie tins,
- Plastic Juice bottles
- Juice cans
- Clean food wrap
- Yogurt containers
- Salted dressing containers
- Cereal boxes
- Plastic grocery bags
- Pizza boxes – unsold
- Plastic cookie and muffin containers

### Office

- Office paper
- Catalogues, Phone books
- Sticky notes, Scrap paper
- Plastic bags
- Cardboard boxes flattened
- Plastic wrapping, Paper bags

**Items not accepted**  
Styrofoam, ceramics, light bulbs, soiled cardboard, hazardous chemical containers, scrap metal, car parts, plastic toys or household garbage

[www.loraasdisposal.com](http://www.loraasdisposal.com)



**SARRC**  
Saskatchewan Association  
for Resource Recovery Corp.

# EcoCentre Building

North Valley Waste Landfill, Fort Qu'Appelle

For more information:  
[www.northvalleywaste.ca](http://www.northvalleywaste.ca)  
<https://usedoilrecycling.sk.com>

## ACCEPTED NO CHARGE

### ACCEPTABLE OILS:

Petroleum-based or synthetic oil typically used in:

- Engines
- Manual or automatic transmissions
- Differentials, transfer cases, gear boxes
- Power-steering
- Hydraulics
- Compressors

### ACCEPTABLE ANTIFREEZE:

Ethylene glycol used in engine or cooling/antifreeze applications.  
\*\*\* Propylene glycol (i.e. plumbing/RV antifreeze) is not accepted \*\*\*

### ACCEPTABLE OIL FILTERS:

- Spin-on, sump, element-style or cartridge-style used on engines, transmissions, hydraulic applications
- Coolant filter
- Diesel fuel filters
- Fuel filters used on diesel fuel storage tanks or pump islands
- Fuel filters used on home furnace fuel tank
- Plastic/paper element-style oil or fuel filters

### ACCEPTABLE CONTAINERS:

- Original plastic oil containers:
  - 250 mL - 50 L that hold the acceptable types of oil
- 2-cycle oil containers
  - exc. from snowmobile / outboard motor oil
- chain or saw guide oil containers
  - exc. from oil used to oil chain-saw chains, machinery chains, or saw-guide bearings
  - metal-working or drill-bit oil containers
    - exc. from oil used to cool drill bits
- antifreeze containers
- diesel exhaust fluid containers

## UNACCEPTABLE MATERIALS

These may be accepted within other recycling programs at the landfill

- Cooking oil or animal fats
- Diesel fuel
- Gasoline, kerosene
- General household plastics
- Grease and cartridges
- Paint, stain, or paint thinner
- Pesticides and containers
- Rust treatments and containers
- Solvents and degreasers
- Spray cans/aerosols
- Turpentine
- Under-coatings or tar
- Varnish or urethane coating
- Water if over 5% by volume in the oil
- Wax
- Windshield washer containers
  - These should be recycled with general household plastic when possible
- Engine air filters
- Furnace air filters

# Household Hazardous Waste – North Valley Waste Management Authority

## ✓ ACCEPTED *Must be in original container with original label (s)*



### • PESTICIDES

- Poison symbol
- “Domestic” not agricultural nor industrial
- PCP (poison control product) #
- Max container size 10 L
- Max aerosol can 680g / 24 oz



### • TOXICS

- Poison & Danger Symbols
- Max container size 10 L
- Max aerosol can 680g / 24 oz
- Example:
  - Automotive additive
  - Furniture stripper
  - Tar and bug remover
  - Weed/Pest killer (Killlex, Round-up)



### • CORROSIVES

- Corrosive symbol
- Max container size 10 L
- Max aerosol can 680g / 24 oz
- Example:
  - Grout/Masonry/Concrete cleaner
  - Muriatic/Battery Acid
  - Bleach/Products with bleach
  - Hydrogen Peroxide
  - Hypochlorite-containing products
  - Pool and hot tub cleaners (algae remover, chlorine & bromine pucks)
  - Calcium/Lim/Rust remover



### • FLAMMABLE LIQUIDS

- Flammable symbol
- Max container size 10 L (25L for gas can/jerry can)
- Max aerosol can 680g / 24 oz
- Example:
  - Gasoline (must be in ULC-approved gas can/jerry can)
  - Acetone
  - BBQ lighter fluid
  - Camp stove fuel
  - Fondue fuel
  - Flammable degreasers
  - Flammable fuel treatment and additives
  - Flammable lubricants
  - Kerosene
  - Methanol
  - Methyl hydrate
  - Mineral Spirits
  - Paint stripper / thinner
  - Paint and varnish remover
  - Turpentine
  - Varsol
  - Other flammable solvents



### • PHYSICALLY HAZARDOUS PRODUCTS

- Flammable symbol & Explosives symbol
- Max container size 5 kg
  - Example:
    - Non-refillable fuel cylinders
      - Butane cylinders
      - Camping cylinders
      - Propane cylinders

## ✗ NOT ACCEPTED

- Non-hazardous materials
- Unidentifiable, unknown, unlabelled and non-original containers
- Leaking / improperly sealed containers
- Ammunition
- Down the drain toxic products
- Medical sharps
- Fertilizers
- Mercury switches
- Powder forms of masonry products (cement, grout)
- Caulking compound
- Cement
- Commercial / Industrial / Agricultural Products
- Cosmetics and beauty products
- Drugs, medicines and other health products (hand sanitizers)
- Diesel
- Mortar, plaster of Paris
- Refillable propane cylinders
- Wine and distilled spirits